

### Networks with Repeaters

By H. Moholdt

#### Keywords

- Radiocrafts RF modules with embedded protocol and UART interface
- Simple repeater implementation without external components
- Addressing features embedded in RC1xx0 and RC2x00 modules
- Dividing network in channels

#### Introduction

The RC1xx0 and RC2x00 series of RF Modules with integrated protocol offers easy adaptation of wireless communication utilizing a simple UART serial interface. By using the embedded multi-channel utilities and the addressing features and by introducing repeaters, large and complex networks with outstanding range can be configured.

#### Simple Repeater Building Block

The asynchronous UART interface on Radiocrafts modules is an easy-to-use interface towards microcontrollers or RS232/422/485 levelshifters. As the received data is clocked out on the TXD pin on the module it can also be read directly by the RXD pin on another module without any buffering circuitry as shown in the figure below.

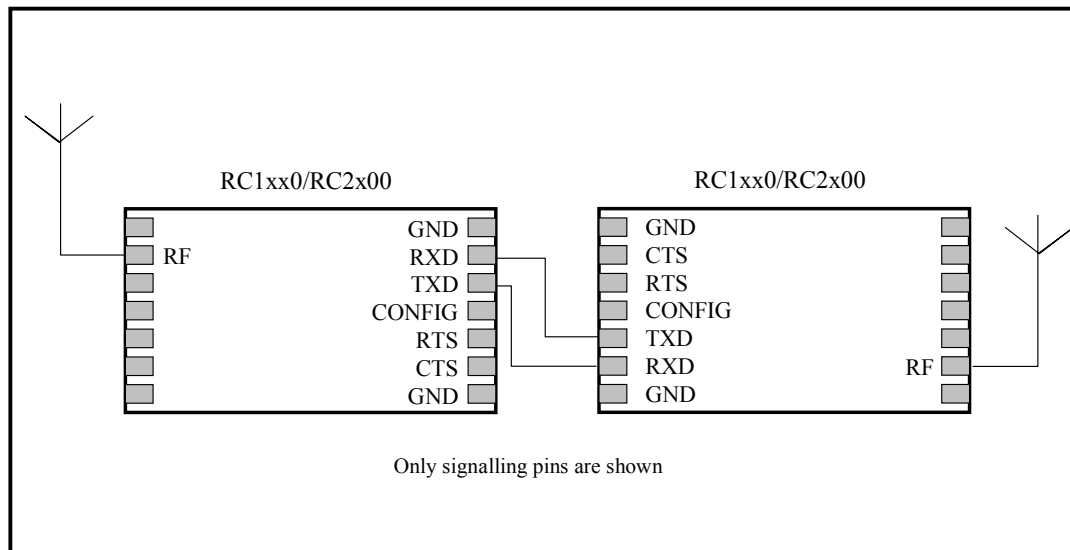

The second module will then re-transmit the incoming packet on what can be seen as a secondary network, which can be on another frequency or on the same frequency but with different addressing. This simple repeater will in practice double the range when inserted in a link for repeating purposes.

### Embedded addressing features in RC1xx0 and RC2x00 modules

The Radiocrafts RC1xx0 and RC2x00 family has built-in addressing features and multi-channel frequency configuration. Please see the RC232 User Manual on how to configure and store these parameters in the configuration memory.

The RC232 protocol includes the following main IDs for addressing:

- SID = System ID; One byte defining a System ID. All modules in the network must have the same SID to be able to communicate.
- UID = Unique ID; One byte defining a Unique ID for each module in the system. Several modules may have the same UID, but normally the broadcast address should be used (see RC232 User Manual) if all modules in a network (with same SID) shall receive the same message.
- DID = Destination ID; One byte defining the address for the receiver/destination of the data package. The module(s) with corresponding UID will pick up and decode the RF package and deliver the received data on its UART TXD-pin.

Default value from factory for both SID, UID and DID is 0x01 so no address configuration is needed for setting up a two-way link, point-to-point or point-to-multipoint.

### Complex networks with repeaters

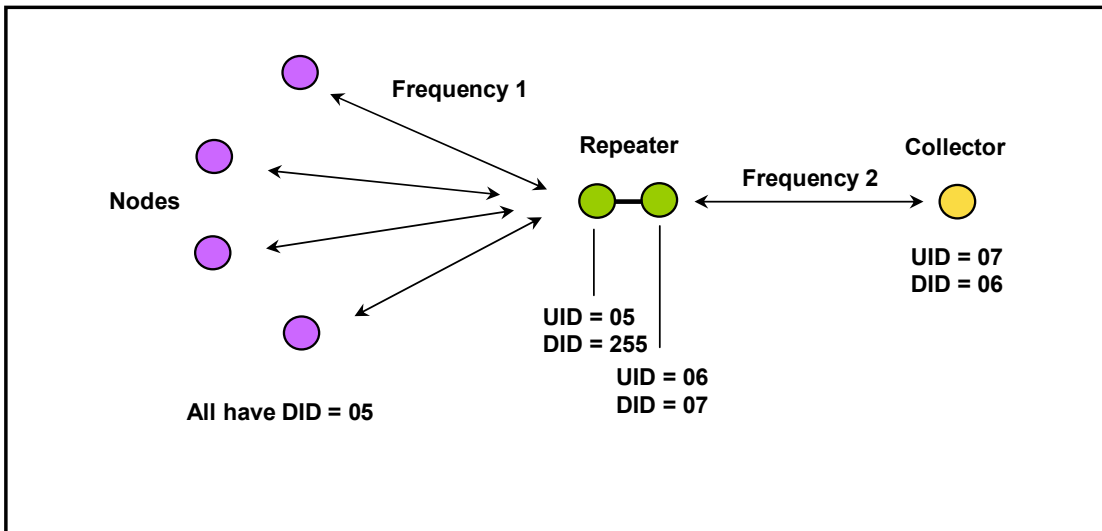

NOTE: All nodes have identical SID. All purple nodes have BROADCAST\_ADDRESS = 255 (default setting)

Referring to the figure above, a typical setup for frequency separation and/or addressing is shown. The two modules making up the Repeater are marked green.

As easily seen, when the Repeater is omitted the data Collector and Nodes make up a traditional star point-to-multipoint network. The Repeater just extends the range.

As shown in the system above, the four purple Nodes all have DID = 05, i.e. the data packets from these will be received by the first module in the Repeater. The data from the Nodes will then be re-transmitted by Repeater-module 2 with DID 07, and will finally be received by the data Collector (yellow colour).

In the other direction, if the collector is sending packets to the Nodes, the possibility for direct addressing to unique Nodes is lost, as the addressing is only one level deep. Thus, in the addressed setup above, the Collector sends its data to Repeater module 2, connected to module 1 over its UART. Module 1 re-transmits with DID = 0xFF (255 is default)

BROADCAST\_ADDRESS in all modules but can be configured to any value within 1 byte). Data from Collector will then be read by all Nodes.

Of course, if there was only one Node to receive data from Collector, direct addressing from Repeater module 1 can be used instead of broadcast by making a matched pair of UID and DID for this link.

External addressing in several levels can easily be implemented by adding extra addressing-bytes in the payload with the destination address of the package. An additional microcontroller or other intelligence would then decide whether the received payload of the package has reached correct address or shall be neglected.

### Channel Usage

If the modules embedded addressing features are used in different areas of the system, all modules can operate on the same frequencies/channels. If full broadcast is used or addressing is disabled, frequency planning like the one shown (different frequencies before and after a repeater) is mandatory to avoid system self-jamming.

### Repeater Practical Notes

The repeater will usually be powered via the mains. As stated in the datasheet, proper power on reset is only secured by the required steepness in VCC raise time. If powered via an AC/DC adaptor, please note that the rise time will be in the ms-range and make sure to assert RESET after power-on as specified in the datasheet.

### Document Revision History

Document Revision	Changes
1.0	First release

### Disclaimer

Radiocrafts AS believes the information contained herein is correct and accurate at the time of this printing. However, Radiocrafts AS reserves the right to make changes to this product without notice. Radiocrafts AS does not assume any responsibility for the use of the described product; neither does it convey any license under its patent rights, or the rights of others. The latest updates are available at the Radiocrafts website or by contacting Radiocrafts directly. As far as possible, major changes of product specifications and functionality, will be stated in product specific Errata Notes published at the Radiocrafts website. Customers are encouraged to check regularly for the most recent updates on products and support tools.

### Trademarks

RC232™ is a trademark of Radiocrafts AS. The RC232™ Embedded RF Protocol is used in a range of products from Radiocrafts. The protocol handles host communication, data buffering, error check, addressing and broadcasting. It supports point-to-point, point-to-multipoint and peer-to-peer network topologies. All other trademarks, registered trademarks and product names are the sole property of their respective owners.

### Life Support Policy

Radiocrafts products are not designed for use in life support appliances, devices, or other systems where malfunction can reasonably be expected to result in significant personal injury to the user, or as a critical component in any life support device or system whose failure to perform can be reasonably expected to cause the failure of the life support device or system, or to affect its safety or effectiveness. Radiocrafts AS customers using or selling these products for use in such applications do so at their own risk and agree to fully indemnify Radiocrafts AS for any damages resulting from any improper use or sale.

© 2005, Radiocrafts AS. All rights reserved.

### Contact Information

Web site: [www.radiocrafts.com](http://www.radiocrafts.com)

Email: [radiocrafts@radiocrafts.com](mailto:radiocrafts@radiocrafts.com)

Address:

**Radiocrafts AS**  
Sandakerveien 64  
NO-0484 OSLO  
NORWAY

Tel: +47 970 86 676  
Fax: +47 22 71 29 15